

SECTION A-A

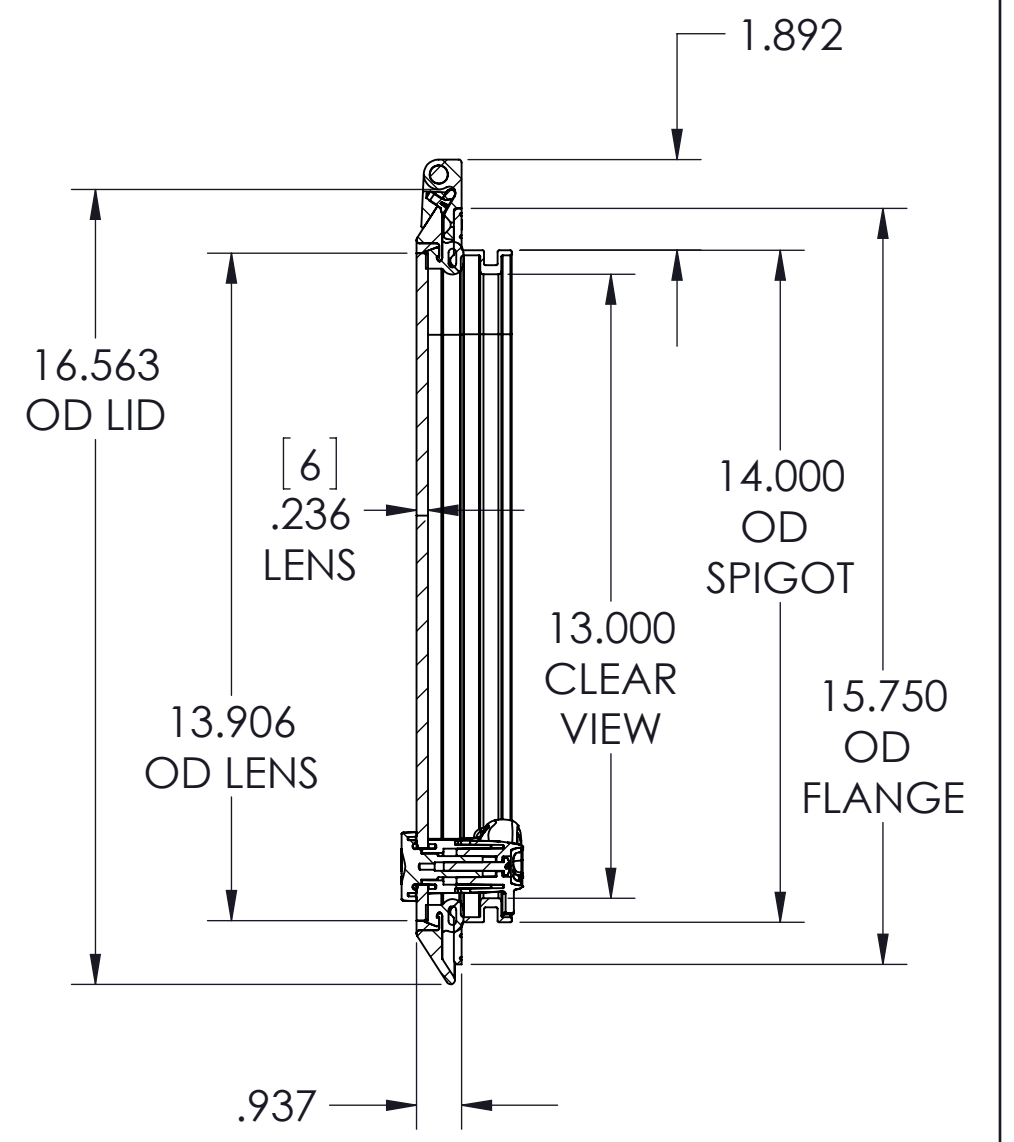

SECTION B-B

NOTE:  
SUGGESTED CUTOUT = 14-1/8 X 14-1/8  
CUTOUT RADIUS = 1-11/16 RADIUS

REVISIONS			
REV.	DESCRIPTION	DATE	APPROVED

<small>THIS DRAWING IS THE PROPERTY OF POMPANETTE, LLC. CHARLESTOWN, N.H. ALL RIGHTS ARE RESERVED. THIS DRAWING AND INFORMATION MAY NOT BE COPIED OR DISCLOSED TO OTHERS WITHOUT WRITTEN PERMISSION OF POMPANETTE, LLC.</small>				<small>DIV. OF Pompanette INC. 73 SOUTHWEST ST. PO BOX 1200 CHARLESTOWN, N.H. 03803 PH: (603) 826 5791 FAX: (603) 826 3074</small>	
TOLS. ±1/64	TITLE LOW PRO HATCH ASSEMBLY WITH 'A' TOP				
FRAC. .XXX = ±.005	SEE BOM		JPERRY		1 OF 1
DEC. XX = ±.01	MATL.	DRAWN BY	N1060-10A		
DEG. ±1°	SCALE 1:4	SIZE ©	DATE 1/2/13	PART NO.	